



ULTRAPLY™ TPO





TOP FIVE BENEFITS OF ULTRAPLY™ TPO



ENHANCED ENERGY EFFICIENCY

- White Elevate UltraPly™ TPO surface exceeds the EPA's requirements
- White, tan and gray options are listed with the Cool Roof Rating Council (CRRC)
- The white option is in compliance with California's Title 24 Energy Efficiency Building Standards and can be used to gain credits with Leadership in Energy and Environmental Design (LEED®) certification



LESS ENVIRONMENTAL IMPACT

- Elevate™ manufacturing plants are ISO-9001-certified and supply regions across the Americas
- Proximity of product availability reduces greenhouse gas emission and contributes to energy conservation
- Does not contain chlorinated or halogenated components
- Can add LEED points to the design, construction, operation and maintenance of a commercial building

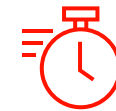

LONG-LASTING PERFORMANCE

- Resists degradation from ultraviolet (UV) radiation and ozone
- Guards against erosion from harmful chemicals and microbial growth
- Performs at more than three times the ASTM International standard for weathering resistance



EXCELLENT WIND UPLIFT RESISTANCE

- Elevate provides an array of TPO systems to meet the most demanding wind uplift requirements
- FM certified systems up to 720 psf
- Roofing systems tested per CSA A123.21 dynamic wind uplift resistance

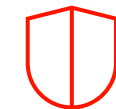

EXCELLENT DURABILITY AND STRENGTH

- Average thickness over scrim meets ASTM D6878 standard on 45-mil, 60-mil and 80-mil, which helps protect against punctures, tears, and abrasion
- UltraPly TPO provides protection against hail damage, achieving Factory Mutual (FM) approval for Very Severe Hail for over 500 assemblies, and more than 14,000 Severe Hail assemblies

ELEVATE™ ULTRAPLY™ TPO

Exceptional building performance starts at the top.

Significant reduction in roof surface temperature. Greater energy efficiency, more indoor comfort and lower electricity bills. It's no surprise that thermoplastic polyolefin (TPO) roofs are the fastest growing, sustainable commercial roofing products available. And with more than two decades of TPO experience, Holcim proudly stands behind our family of UltraPly™ TPO products.

Our TPO formulation helps to ensure long-term roof performance with properties that provide excellent weathering, ozone and chemical resistance. It has remained unchanged since 1996. Plus, UltraPly TPO is environmentally friendly, offers excellent puncture resistance (especially against hail) and has lower installed costs than other commercial roofing membranes.

ULTRAPLY™ TPO SYSTEMS

ULTRAPLY™ TPO

ULTRAPLY™ TPO PLATINUM™

ULTRAPLY™ TPO SA

ULTRAPLY™ TPO XR

ULTRAPLY™ TPO INVISIWELD™

ELEVATE LIMITED WARRANTIES*



* Conditions apply. See holcimelevate.com for details

ULTRAPLY TPO PLATINUM™ SYSTEMS

Extend your roof life – and peace of mind.

Elevate UltraPly TPO Platinum™ systems are backed by up to 30-year limited warranty. Comprised of a durable, 80-mil-thick scrim-reinforced membrane, the UltraPly™ TPO Platinum system can be fully adhered or mechanically attached to Elevate insulation and fastened to a wide range of deck substrates.

In addition to long-lasting performance, UltraPly™ TPO Platinum Systems deliver:

- Excellent field seams and high-wind ratings
- FM VSH approved
- Chlorine and halogenate-free components
- Exceeds EPA's requirements (white only)
- Variety of warranties including cut and puncture protection, hail and increased wind speed

ULTRAPLY TPO PLATINUM™ PRODUCTS

ULTRAPLY TPO PLATINUM™ MECHANICALLY ATTACHED

1. Elevate UltraPly TPO Platinum Membrane
2. Appropriate Elevate Mechanical Attachment
3. Appropriate Elevate Fasteners
4. Appropriate Elevate Insulation
5. Elevate Vapour Barrier
6. Roof Deck

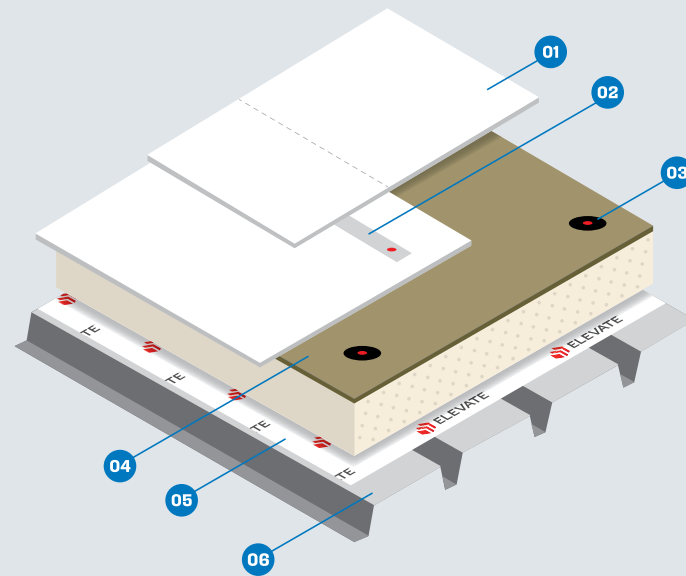

ULTRAPLY TPO PLATINUM™ ADHERED

1. Elevate UltraPly TPO Platinum Membrane
2. Elevate UltraPly TPO Bonding Adhesive
3. Appropriate Elevate Fasteners
4. Appropriate Elevate Insulation
5. Elevate Vapour Barrier
6. Roof Deck

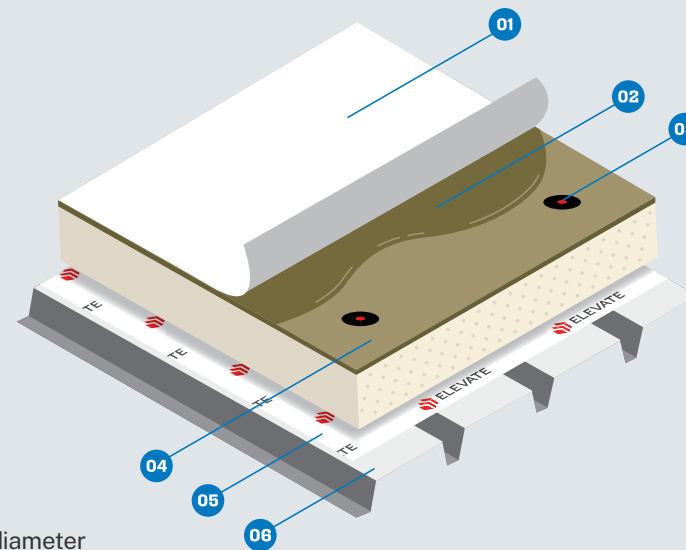

MULTIPLE TYPES OF PLATINUM LIMITED WARRANTIES AVAILABLE

- Puncture: Coverage for incidental punctures
- Puncture/hail: Coverage for punctures and hail up to 2" diameter
- Puncture/hail/wind: Coverage for punctures, hail and 120 mph wind

ULTRAPLY™ TPO SA WITH SECURE BOND™ TECHNOLOGY

Elevate UltraPly™ TPO SA with Secure Bond™ Technology is a self-adhering membrane with a revolutionary, factory applied, pressure sensitive adhesive that increases the number of square feet that can be installed in a day, enabling contractors to finish jobs more quickly and get to more jobs in the year. Designed to be the next generation in fully adhered roof system applications, Elevate Secure Bond™ Technology ensures uniform adhesion coverage across the entire membrane, creating the most powerful bond over the broadest temperature range. This advanced technology significantly improves installation speed of adhered TPO systems and widens the weather window, with the ability to install down to 20°F / -7°C.



COLD WEATHER INSTALLATION

- Significantly expand your annual installation window, even down to 20°F / -7°C with outstanding adhesion



INSTALLATION SPEED

- Installs up to four times faster than adhered applications depending on ambient conditions



ODORLESS & SAFE

- With zero Volatile Organic Compounds (VOCs), Secure Bond Technology is compliant with all state / province VOC regulations, is safer for the contractor, building occupants and the environment

SECURE BOND TECHNOLOGY

- Meets or exceeds all ASTM requirements
- UL and FM tested and approved
- Covered Elevate Red Shield™ Limited Warranty up to 20 years



ELEVATE ULTRAPLY™ TPO XR

UltraPly™ TPO XR is reinforced with eight-ounce, nonwoven polyester fleece, combining the attributes of UltraPly TPO membrane with a fleece backing.

FEATURES AND BENEFITS

- Three thickness options – XR 100 (45-mil), XR 115 (60-mil) and XR 135 (80-mil), laminated to a 55-mil nonwoven polyester fleece
- FM VSH approved for XR 115 and XR 135
- Quick and easy installation methods, especially efficient for large areas
- Elevate LVOC low-rise foam adhesive options (XR Stick™, Twin Jet and I.S.O. Spray™ R Adhesives) are specifically designed for use with UltraPly TPO XR membrane
- Strong cut and puncture resistance, enhancing sustainability
- Excellent resistance to microbial growth, environmental pollutants and UV rays
- CRRC-rated and may contribute to LEED points
- Ideally suited for reroof applications and new construction
- Variety of warranties including cut & puncture protection, hail and increased wind speed. Warranted installation applications include hot asphalt.





ULTRAPLY TPO INVISIWELD™

High-performance, non-penetrating TPO membrane fastening system

Elevate UltraPly™ TPO InvisiWeld™ System is a high-performance, non-penetrating mechanically attached system that provides high wind uplift ratings with a more balanced load distribution across the entire roof. Installation is simplified and requires less material for perimeters and corners than other attachment methods.

This VOC-free application features Elevate UltraPly TPO InvisiWeld plates attached to the UltraPly TPO membrane using an induction welding tool. The InvisiWeld System achieves FM approvals.

The roofing season can be extended since the InvisiWeld System functions well in many climates, including cold environments where adhesives and asphalt may be difficult to use. The system reduces the need for insulation plates and fasteners.

ULTRAPLY™ TPO ACCESSORIES

Holcim is proud to provide our customers with a line of Elevate UltraPly™ TPO membranes and accessories that are backed by a history of excellence and the exclusive Red Shield™ Limited Warranty.

ADHESIVES & PRIMERS

- UltraPly Bonding Adhesive
- Water Based Bonding Adhesive
- Single-Ply LVOC Bonding Adhesive
- Single-Ply LVOC Bonding Adhesive 1168
- UltraPly TPO XR Bonding Adhesive
- XR Stick™ Adhesive
- I.S.O. Spray XR Adhesive
- Twin Jet Adhesive
- Single-Ply QuickPrime™ Primer
- Jet Bond Spray Adhesive
- Single-Ply LVOC Primer

QUICKSEAM™

Weld-free accessories with pre-applied adhesive

- UltraPly TPO QuickSeam 5.5" & 9.5" Flashing
- UltraPly QuickSeam RMA Strip
- UltraPly QuickSeam RPF Strip
- UltraPly QuickSeam T-Joint Covers
- UltraPly QuickSeam Pipe Boots
- QuickSeam Yellow Safety Strip

ULTRAPLY TPO SYSTEMS OVERVIEW

TYPE	THICKNESS	WIDTHS	APPLICATION METHODS	SEAMS	COLORS AVAILABLE
UltraPly TPO	45, 60, 80 mil	5', 8', 10', 12'	Adhered, Mechanically Attached, InvisiWeld, or Ballast	Heat weld	White Tan Gray
UltraPly TPO XR	100, 115, 135 mil	10'	Adhered or Mechanically Attached	Heat weld	White Tan Gray
UltraPly TPO SA	60 mil	10'	Self Adhered	Heat weld	White Tan Gray



Learn more at www.holcimelevate.com.

© 2023 Holcim Solutions and Products US, LLC
Holcim Solutions and Products Canada, a Division of Lafarge Canada Inc. All Rights Reserved.

5 / 2023